

ARCAristics

CUSTOMER MAGAZINE FOR LEADING CONTROL TECHNOLOGY 06.2023

ROCKET SCIENCE - MADE BY ARCA



PROLOGUE

“Everything changes, but behind it rests an eternal.” What the poet, thinker and naturalist *Johann Wolfgang von Goethe* wrote in a letter to *Katharina Fabricius* in 1770 still holds true today.

In all the changes and crises that we in Europe and the world are in the midst of as a networked whole, we have to work at full speed and with confidence on new solutions, because the said “eternity” can only be achieved through a sustainable, resource-preserving and regeneratively oriented economy (and society). As thinkers and engineers we want to contribute to that.

We hope you enjoy reading!



CONTENTS

PROLOGUE	02
CONTENTS	03
ARCA IN SPACE	04
ARCA REGLER GMBH	
Green heat in Wismar	08
Control valve reincarnation	09
Evolution of the forged valves	10
Smart Controlling	11
What you save: 9,900 seconds!	12
Welkom aan boord	13
Turning point for supply chains	14
We've got a couple of questions	16
Four for a hellolujah!	18
ARTES VALVE & SERVICE GMBH	
Dehydrate and desalinate please	20
FELUWA PUMPEN GMBH	
The Colossus of Mürlenbach	21
FELICS® – it doesn't get any cleverer than this	22
Growing on the job: PCG SMART Compact	23
Service 4.0	24
VON ROHR ARMATUREN AG	
Swiss precision work	25
WEKA AG	
Hydrogen expertise since 2005. For 2055.	26

ARCA IN SPAC

Thanks to hydrogen –
the energy to lift off

ARCA was also part of the team at the start of the latest launcher generation ARIANE 6. Engineering Excellence is in demand here, near the city of Kourou in French Guiana. A reliable supply under the highest loads has to be guaranteed at the rocket launch pad of the European Space Agency ESA. Our valves are installed in the fuel filling system, where they ensure that helium, oxygen, nitrogen and hydrogen are fed reliably into the fuel tanks of the rockets.

- Approx. 30 ARCA 8C ECOTROL® control valves
- Series 8C nominal size 2" – 3" Class 300
- Special corrosion protection of the valves according to corrosion class C5 according to EN ISO12944
- Use of the intelligent, explosion-proof ARCAPRO® type 827A positioner

The new ARIANE generation 6 with a height of 63 m and an expected starting mass of 530 t will be propelled into space by about 30 million HP of thrust. The required huge flow of the fuel components takes place in just a few minutes. The proven ECOTROL® series has been in use there since the start of the ARIANE program. The modular design of these control valves ensures in various positions in the ground supply system that all control processes meet the highest safety requirements. Let's take a detailed look at this high-performance system.

Hydrogen and oxygen are required as fuel for the ARIANE so that the launch weight of almost 800 t (configuration of the Ariane 64) can be accelerated to up to 10,400 m/s and brought into the interplanetary trajectory. At that speed the distance between Frankfurt and New York could be covered in 10 minutes.

The ECOTROL® series is suitable for such stresses.



The version for the ESA operation in Kourou has the following specifications: The bonnet seal between the body and bonnet is in the off-load area and meets the highest requirements in order to guarantee the external leak-tightness. The maintenance-free stem packing is technically permanently leak-tight with a special PTFE compound and is certified according to TA-Luft / ISO 15848. This packing consists of various PTFE compound rings, making it insensitive to strongly fluctuating operating pressures.

The ECOTROL® soft seal for the internal leak-tightness has also proven its reliability in an impressive way even with pressure swing stresses. The materials are chosen with regard to hydrogen embrittlement and the explosive decompression of sealing materials. Hydrogen is highly explosive: our valves and accessories are suitable for use in atmospheres at risk of explosion.

The ARIANE Group and its experts are responsible for the new generation of the launcher. Scan this QR-code to see details of the ARIANE mission:



For the outdoor installation at the launch pad on the Atlantic coast in Kourou (French Guiana), the valves were provided with special corrosion protection of the corrosion class C5 according to EN ISO 12944. With our certified coating system the valves are suitable for installation in coastal or offshore areas with a high salt load. In addition, an approved coating system is provided for use in areas at risk of explosion.

All connecting elements for the compressed air supply to the pneumatic multi-spring actuator type 812 as well as the accessories are made of austenitic material. The advantageous composition of alloying elements results in outstanding corrosion resistance of the material, making it particularly suitable for use in coastal and offshore areas.

The intelligent, explosion-proof ARCAPRO® type 827A positioner is vibration-proof, mounted directly on the yoke of the valve without external piping and provides for maximum operating safety.

ARCA's range of valves for the space and hydrogen infrastructure is rounded off by very special and sophisticated valves and cryogenic components from WEKA AG. These also meet the stringent quality requirements for safety in the ESA fuel filling system and underline our claim to Engineering Excellence.

Things start moving at the space center in Guiana from the 4th quarter onwards. Six launches are planned for 2023. Go, Ariane, go!



Artist's impression of the European launchers
(© ESA / D. Ducros)



Space-X, the first reusable launch vehicle, does not take off without ARCA's control technology.

With a planned thrust of 7,600 t, the rocket can say goodbye to gravity and Mother Earth – and then return to Earth later as the first launcher system to do so. We are proud to be part of the process control with our technology.

ARCA supplies the private American space travel company with ECOTROL® blow-off valves for a total of four Main-Air-Compressors (MAC), which are integrated in air distillation plants from LINDE for the generation of pure oxygen, one of the main components of rocket fuel.

The planned rocket consists of the booster *Super Heavy* and an upper stage called *Starship*, which is also intended to serve as a spaceship.

Both stages are propelled by engines of the type *Raptor*. The goal is the development of a completely reusable and lower-cost launch system for a payload of over 100 metric tons that is intended to replace all other rockets operated by SpaceX in the long run.

The *SpaceX South Texas Launch Site*, also called *Starbase* for short, is a spaceport near Brownsville in Texas, USA that is still under construction. The owner and operator of the facility is the American space travel company SpaceX.

As far back as 2017, the company's CEO *Elon Musk* presented the rocket, with which a manned mission to Mars is to be made possible, to the public. Among other things, it is to be used to place satellites in orbit and to carry supplies to the International Space Station or a future base on the moon.

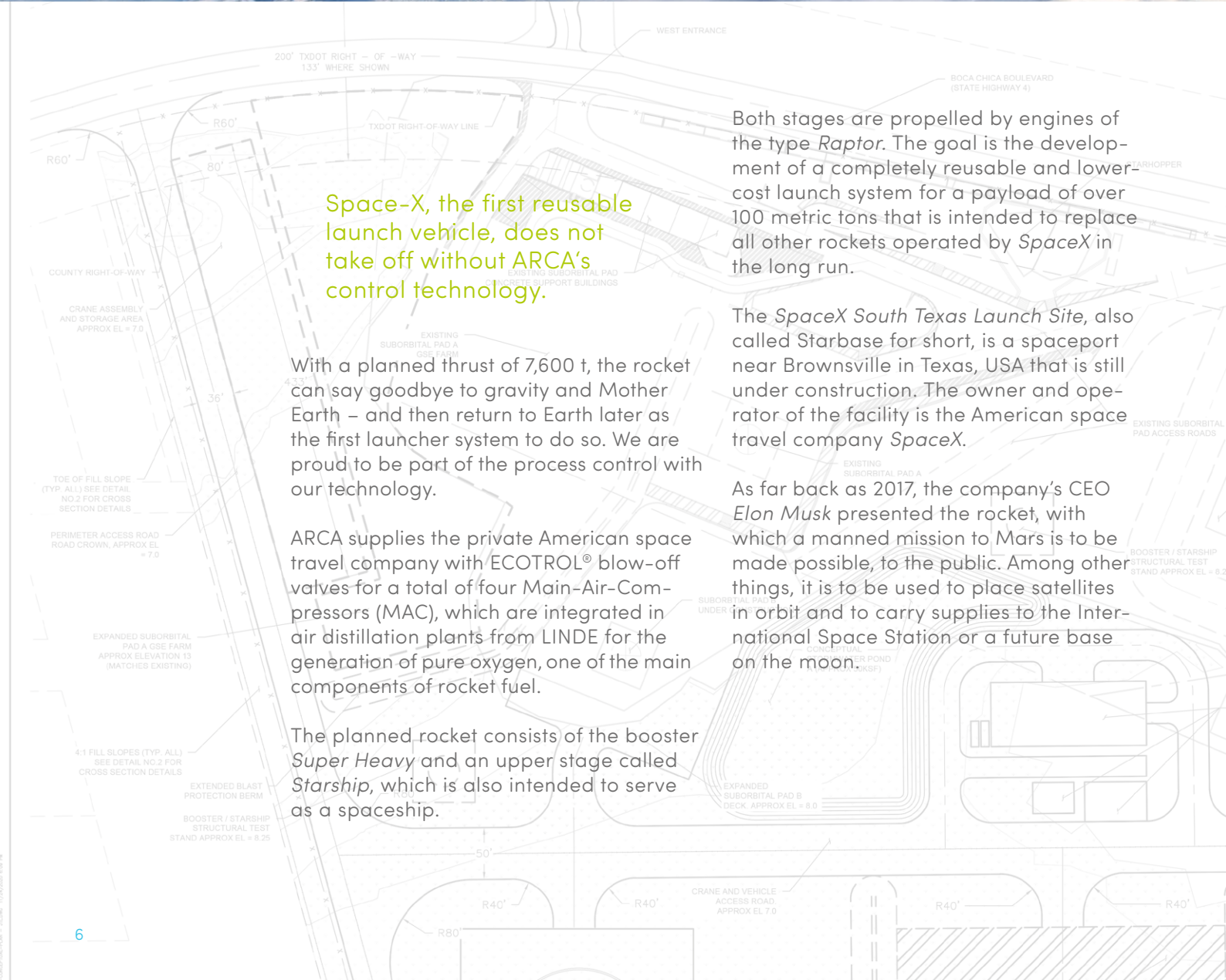

GREEN HEAT IN WISMAR

A combined heat and power plant in Wismar generates pellets

In 2022, ARCA was commissioned by a plant manufacturer to supply valves for the steam conditioning of the Wismar Pellets biomass power plant. Thanks to our expertise in this demanding safety application, ARCA was able to win the contract ahead of two renowned competitors. The biomass power plant – a combined heat and power plant in the seaport of Wismar, approx. 30 km north of Schwerin – produces heat and green electricity. Using the heat from the combustion of solid biomass, Wismar Pellets will dry its raw materials in a more environmentally friendly and less expensive way from now on.

In addition to the usable heat, the generated steam will be used in a turbine to drive a generator and convert mechanical energy into electrical current.

The steam-conditioning stations and the pressure reducing valve were manufactured as safety-oriented quick closing valves according to EN12952-10 with SIL. In addition to the requirement for precise pressure and temperature control, the valves close in less than 2 seconds in the case of inadmissibly high pressure and temperature in the outlet pipeline after the valve. The pressure and temperature monitoring and safety triggering are handled by the steam test units.

So that this exemplary green energy project continues to be controlled efficiently and run safely, the operator took out a maintenance contract with the ARCA service experts that guarantees regular on-site service visits.



The scope of delivery encompassed:

- Three POWERCONTROL series 560 steam conditioning stations with the corresponding ECOTROL® series 8C cooling water control valves
 - A steam diffuser for reducing the pressure of the outlet steam from the steam conditioning station into the vacuum of the condenser
 - An ECOTROL® series 6H pressure reducing valve with downstream POWERCONTROL series 595 mini cooler for temperature reduction with the corresponding ECOTROL® series 8C cooling water control valves
 - Blow-off inserts to protect the steam conditioning stations during the cleaning of the pipelines
 - Four steam test units to protect the pipeline against inadmissibly high pressure or temperature after the steam conditioning
-

CONTROL VALVE REINCARNATION

How to generate new plant components from old ones

The strengths of a modern and flexible mid-size company with a high depth of production like ARCA Regler GmbH come into their own when we talk about customizing and lot size 1 in machine and plant manufacturing.

In the following project for the chemical industry, the challenge for a single design was particularly big. The task was to re-design a no longer available 3-way valve with extreme flow guidance for use in areas at risk of explosion.

Plant operators are regularly confronted with the challenge of replacing old plant components. Either the plant components are no longer repairable due to their condition, or the spare parts can no longer be obtained for a further repair. The challenge gets a whole lot bigger if spare units are also no longer available from the original manufacturer. That's why many valve manufacturers are hesitant when they receive enquiries for the replacement of older special valves. Not with ARCA.

Therefore, for the replacement of a 3-way valve that was no longer available, we were commissioned with redesigning and supplying such a special valve. The methane gas flow enters centrally and is fed either to the process or to the flare. The inlet and the two outlets lie in one plane.

The big challenge was not only to adhere to the original manufacturer's installation length, for which a new casting model was made especially for the housing, but also to make sure during the modeling of the valve body that the required flow rate of 380 m³/h could be ensured despite the extreme flow deflection. In view of the complex shaping of the surfaces, the modeling of the exterior and interior surfaces could only be done separately. The strength examination took place subsequently on the basis of an FEM analysis and the required flow coefficient was confirmed in a separate CFD simulation. Adherence to the ATEX Directive and the SIL suitability were the icing on the cake of a complex valve rebirth.

Such projects emphasize ARCA's strengths demonstratively. Comprehensive consulting is one of the key elements of our offers and solutions and a cornerstone of high customer satisfaction.

Details of this 3-way individual construction:

- Based on the 200 series
- DN 150
- PN 40
- Temperature range -100 °C to 270 °C



EVOLUTION OF THE FORGED VALVES

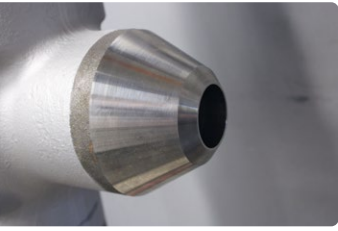

The series 190 enables flexible connections of nominal size DN15 – DN65 to your pipeline

Tight, tighter, tightest

We offer our FORGEVENT series made of solid forged material or forged molded housings in a large selection of housing materials and the associated high density. The high-pressure valve series has now been expanded by a new arrival: the FORGEVENT Series 190.

As an addition to our control valves in the high-pressure range from Class 900/PN100 to Class 2500/PN400, we can impress with short delivery times and high availability as well as service friendliness.

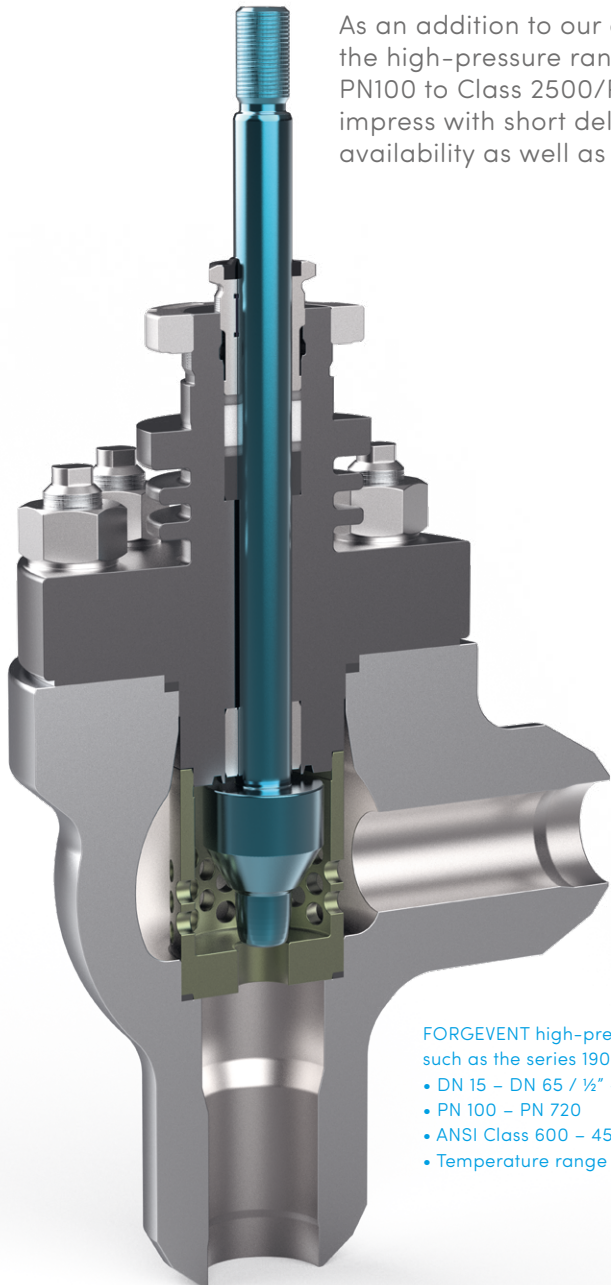

FORGEVENT high-pressure valves such as the series 190

- DN 15 – DN 65 / ½" – 2 ½"
- PN 100 – PN 720
- ANSI Class 600 – 4500
- Temperature range -29 °C to 650 °C

What we mean by service friendliness is just as quick to explain as it is to service the valve itself. The so-called top-entry clamping seat design enables servicing without(!) special tools and the replacement of all wearing parts without(!) replacing the valve. Due to the clamped design, internal leaks between the seat and housing are consigned to the past.

The FORGEVENT series 190 was further developed for the rated working pressure Class 4500 and supplemented by the nominal size DN25. The valves are made of forged solid material or forged molded housings. There is a choice of carbon steels and heat-resistant steels as materials. They meet both DIN and ASME standards and can therefore be used worldwide. The valve can be connected directly to the pipeline from DN15 – DN65 by means of welded ends or welded sleeves.

The series 190 impresses in many plants not least due to its service-friendly design. A typical area of use is the water circulation in power plants, where the FORGEVENT's extremely reliable, robust and precise control comes into its own. Our forged valve also passes every load test as an on/off valve.

Contact us if service-friendliness and leak-tightness are at the top of your list.



SMART CONTROLLING

The Bluetooth adapter: A further step towards the digitalization of the ARCASMART

The control of thermostats and other functions in the house using apps on mobile end devices has long been part of everyday life, and those who are acquainted with and have grown to appreciate the advantages of Smart Home want to enjoy this convenience in their working life, too. That's why ARCA has delivered. Handling is as simple as could be with the ARCASMART digital positioner.

With the aid of the *Sitrans Mobile IQ app* from Siemens AG, the setting and checking of the positioner can be done from your smartphone, tablet or laptop. The positioner and app are connected with each other via Bluetooth. Only a visual connection to the adapter (maximum distance 10 m) is necessary for this.

After a connection is established the initialization, for example, can be performed. Other settings that can be made are the tight closing function or the direction of action. Or perhaps you would like to carry out a leak or speed test to optimize the operation of the positioner. All very easy, and we haven't even mentioned the various diagnostic functions yet.



In addition to information such as the operating hours and the number of load cycles, it is also possible to record the values for the electronics temperature and the loop current as well as a target/actual comparison of the valve position in the form of a diagram. These diagrams can, of course, be saved afterwards and sent for further evaluation. Current values, settings and diagnostic data are also available in the app for downloading, thus providing everything that an analysis needs or that support requests per email.

Last, but not least, several positioners can be operated with the same parameters. Hence, a parameter set can be saved by the master device on the mobile end device and copied to additional devices. Beautiful digital world!

ARCA enables constant simplification, automation and optimization of the commissioning and maintenance processes.

Smart, isn't it?

The combination of smart positioner with Bluetooth adapter and the associated *Sitrans Mobile IQ app* results in a comprehensive controller within the range of vision



WHAT YOU SAVE: 9,900 SECONDS!

An example illustrates the magnitude of this saving: The previous complete testing time for three ANSI 16" valves was 700 minutes – it's now around 200 minutes. The time saving amounts to – fasten your seat belts – about 165 minutes (or 9,900 seconds) per valve.

The new digitally networked test bench with enormous potential

A further major advantage of the new test bench is the automatic transfer of the target data from SAP and that of the actual data to SAP. As a result, neither manual calculation nor the reading of tables is required any more, nor is manual input. Transfer or typing errors are thus eliminated.

After the corresponding start-up time, the target data transfer from SAP and the actual data transfer to SAP will also be implemented on the smaller test benches in Vorst and Strotzbüsch. In addition, the test data including target data and tolerances are recorded so that a target/actual evaluation as well as a qualitative evaluation can be made, which provides information on the extent to which certain valve types really exploit the permitted tolerance range.

This detailed knowledge makes us a little bit better once again and shows that progress in comprehensively digitalized production is reflected in many of ARCA's service and performance parameters.

Last year a new test bench was put into operation at the Tönisvorst site. In comparison with the previous apparatus, the new test bench can accept and test three times the load (2,450 kN). It operates up to 690 bar with water and tests from DN100 PN400 / 4" CLASS 2500 to DN500 PN63 / 20" CLASS 300. Valves larger than DN500 / 20" can also be tested outside of the test bench up to a test pressure of 690 bar. Such new dimensions in testing are advantageous both for us and for our customers, because external testing of large valves can thus be eliminated.

Valves with welded ends can now also be held in the test bench without pressure test plates having to be specially welded on for the test. This means cost savings and approximately two weeks shorter lead times in our production process. Many larger valves also no longer have to be flange-mounted. There are corresponding cost and time savings here, too.



ARCA employee
Markus Würde by the new
test bench

WELKOM AAN BOORD

Of historic valves, maiden voyages and a new place of operation

The *SS Rotterdam* is a former Dutch passenger ship, built by the *Dutch shipyard Rotterdamsche Droogdok Maatschappij*. It is the largest passenger ship ever built in the Netherlands and serves today as a museum and hotel ship.

The ship was built for the *Holland-Amerika-Lijn* and christened in 1958, subsequently being used as a liner on the route between Rotterdam and New York. The passenger ship started its maiden voyage from Rotterdam to New York on 3rd September 1959 with *Crown Princess Beatrix* on board.

And this is where our two sealing steam valves entered into seafaring history. The valves were in operation for almost half a century, controlling the steam circulation in the engine room and, surrounded by the two De Schelde geared turbines and the four oil-fired steam boilers, ensuring the right "flow". The valves were only allowed to retire in summer 2008. At that time, following extensive renovation work, the *SS Rotterdam* was taken to its final resting place. Naturally that is in Rotterdam – moored at the small port peninsula Katendrecht, where it has been open to the public since 2009.

Check into the floating Hotel Rotterdam, Event Ship & Museum and visit our two "oldies" on the guided *Stoom & Chroom Tour*, which also takes you through the engine room.



One of the two ARCA valve oldies that have been in operation in the engine room since 1959

Machine output	25,742 kW (35,000 HP)
Maximum speed	25.0 kn (46 km/h)
Length	228.20 m (overall)
Width	28.70 m
Draft	max. 9.00 m
Tonnage	39,674 GRT
Crew (active service)	776



TURNING POINT FOR SUPPLY CHAINS

Our new delivery promise in times of change

The German economy has thrived for decades on exports. One of the supporting pillars and a global leader is the machine and plant manufacturing industry, so you could also speak of a success story of German engineering. The past years of the pandemic and the criminal Russian war of aggression against the Ukraine have turned the complete global economy upside down. As a Hidden Champion, ARCA Regler GmbH was also partly affected.

The cornerstones of our procurement have been shaken to the bone since 2020. We could no longer rely on concluded contracts and agreements, and many lapsed. The nickel price increased exponentially and the trading of nickel on the stock market was even suspended. Only daily prices were available for steels with nickel content and ARCA was happy to get any supplies of material at all.

Due to the West's sanctions against the Russian aggressor, access to aluminum raw material became impossible overnight. New supply sources for aluminum products had to be found. When this took place following a qualification process, we heard of closed ports or overloads in freight quantities and customs.

Shipping companies postponed their deliveries and freight costs increased exponentially. On top of that, a container ship then got struck crosswise in the Suez Canal for several days and blocked one of the major arteries of international trade.

Even though we had planned ahead in many areas in recent years in order to strengthen our capability to deliver and the trust of our customers, we were still forced to act on a daily basis. Strategic procurement was no longer conceivable. What should we do? How should we plan? How to minimize the vulnerability of the global supply chains and dependencies? Question upon question, to which we had to find new answers. How we dealt with the situation is illustrated in the following.

Availability is the central component for ARCA Regler GmbH – with a special feature: this applies to production lot sizes from one to several hundred and therefore necessitates different strategies. The foundation stone for secure procurement and parts management is already laid at the design stage. The use of standard parts, recurrent parts from construction kits, properties, characteristics and much more are defined here. Overall, the *Make-or-Buy* decision and the *Double Sourcing* strategy take place.

“We are experiencing a turning point in history. And that means that the world will not be the same as the world before.”

(Chancellor Olaf Scholz on February 27th 2022
in the German Bundestag))

The almost 400-meter-long freight ship “Ever Given” gained worldwide fame when it ran aground on March 23rd 2021 in the Suez Canal and in doing so blocked the important shipway between Asia and Europe for six days

On this basis discussions take place with suppliers who deliver raw materials or semi-finished products. Particular attention is paid in this context to lot sizes, transport routes and quality assurance together with the suppliers. For that reason framework contracts are taken out in addition to job-related orders so that both sides have planning security. In addition to the *Near Shorings* strategy, it is above all a network structure that is replacing the previous linear delivery chain.

On the other hand, in-house production is one of ARCA's declared goals. Even if we don't machine everything ourselves, we must have the manufacturing competence in-house. Thus, we concentrate on our know-how parts and tailor our machine investments to them in order to remain competitive against third parties.

In addition to procurement and production, we always keep an eye on logistics by evaluating all transport routes by air, sea, rail and road, because only a holistic consideration ultimately leads to an overall result that we have to defend and evaluate in consideration of sustainability or the *carbon footprint*. Under all these aspects we have defined cost-effective and sensible lot sizes, taking into account minimum order quantities, warehouse capacities, budgeted needs, forecasts and many other things.

These considerations and measures, as well as the strategic preliminary work and the efforts of the last years, are the basis of a new delivery promise, because our quality claim in manufacturing, including secure delivery, is only an ARCA advantage when all parameters mesh cleanly. Only this delivery promise enables our customers to safely control their own processes and fulfil their orders.

Our customer-oriented attitude has always enabled us to develop good solutions. We have now fortified that with new measures and a comprehensive resilience strategy. Hopefully you are convinced at the latest at this point that ARCA Regler GmbH is your partner for leading control technology.

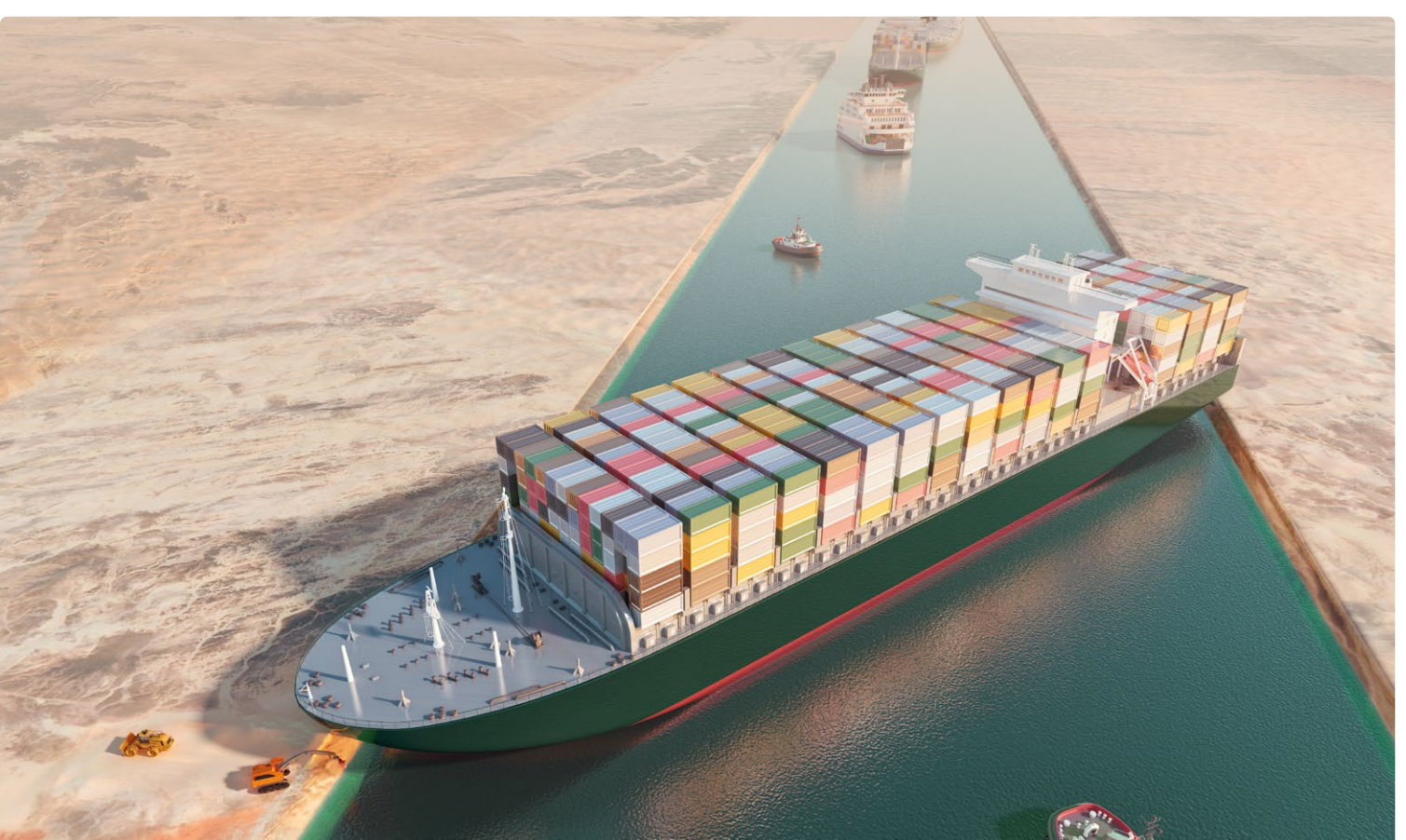

WE'VE GOT A COUPLE OF QUESTIONS ...

... for Heyer & Strobach GmbH & Co. KG and Mr. Möller, Head of Technical Service. The interview was conducted by *Hans Görzen*, Key Account Manager Region West at ARCA.



ARCA: The training/qualification of Heyer & Strobach GmbH & Co. KG on our modular control valves took place in January 2021. How has that affected your daily work?

H&S: We now have greater security in the preparation of quotes for the customer and in the repair of the valves. At the same time, we now have a better detailed knowledge of the ARCA valves. We now know even more precisely what we have to pay attention to when repairing the valves. This know-how has made our technical service more efficient and cost-effective.

ARCA: Simpler tools and no special tools for the repair or maintenance of control valves – how advantageous is that for H&S and its customers?

H&S: Special tools are expensive and, in most cases, only available from the valve manufacturer. That's why we are pleased to be able to save these procurement costs and the additional time factor for the procurement of special tools. That is of course also associated with a reduction in operating costs. The repair of the valves has definitely become more effective through the training carried out by ARCA. However, this also has to do with the well thought-out valve design (clamped seat).

ARCA: Has the replacement of components gotten faster? That includes assembly/disassembly and more generous stocking by ARCA?

H&S: Yes, components are quicker to replace. We save a particularly large amount of time when assembling the ARCA valves. Spare parts are delivered promptly, especially in the standard area of the ECOTROL® type 8C series.

ARCA: Are the certification and the results, including in relation to time and costs, recognized by your customers as advantages?

H&S: The certification was acknowledged positively by our customers. Our customers ultimately benefit from getting a valve back that has been repaired professionally thanks to the skills that our employees have acquired. It is advantageous that fixed contacts are now available at a technical and commercial level. Communication has thus become considerably faster and more efficient. The end customers also benefit from that.

ARCA: Is a refresher training course after a certain period of time of interest to you?



Mathias Möller (42), Head of Technical Service at Heyer & Strobach GmbH & Co. KG.

H&S: Yes. In the current cooperation, questions that crop up at short notice are clarified directly. A refresher course would certainly be useful in case of technical changes.

ARCA: Would you like to get handouts of the most important lessons as reminders?

H&S: That would be an additional and useful measure for the workshop employees.

ARCA: Could ARCA tutorials keep the employees' knowledge "fresh"?

H&S: We would welcome this measure a lot and also make use of it, so that our employees' knowledge remains up to date.

ARCA: In summary, from your point of view, what constitutes the advantage of such a certification?

H&S: As a certified professional repair company, we naturally have a great interest in being authorized by a renowned valve manufacturer like ARCA. The acquisition of possible potential new customers stands to the fore here and, of course, the cost-effectiveness concept of saving time and money with an ARCA valve. We have succeeded in that with the qualification.

ARCA: Thank you for this interview.

Do you still have questions about the ARCA Regler GmbH training program?

Would you like more information about our workshops and the associated qualification program?

Send us a mail: service@arca-valve.com

FOUR
FOR A
HELLO
LUJAH!



Four apprenticeships lead at two sites to one goal

Each year ARCA offers various apprenticeships at the Tönisvorst site, where our Research and Innovation Center is located. There is also lots of space for young apprentices to develop and make a flying start at the second site in Strotzbüsch, in the midst of the beautiful Vulkan Eifel.

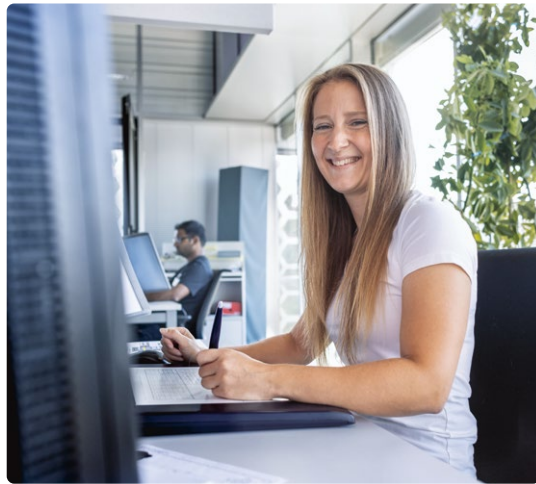

Four of around 200 ARCAians from all over Germany who are delighted at the new arrivals in our team

The trainee skilled workers can choose at both sites in the production area between a career as a CNC lathe operator or industrial mechanic. In Tönisvorst, technical product designers and industrial management assistants are also trained.



Our apprenticeships are an excellent foundation for a successful career start in our mid-sized, internationally aligned, family-owned company. As a *Hidden Champion* with currently around 200 dedicated employees in Germany, we naturally also provide outstanding further development options and individual fostering programs after completion of the apprenticeship. Former apprentices can be found today in many management positions at ARCA.

The ARCA team is in constant "FLOW" and is growing and thriving. It is our mission to enable young people to make a flying start in a promising professional future and, together with them, to set the switches for an ARCA 4.0!



DEHYDRATE AND DESALINATE PLEASE!



Eemscentrale, Eemshaven, NL (©Wutsje/Wikimedia Commons/CC-BY-SA)

High-end valves for 2.4 Gigawatts

The gas and steam combined *power plant Eemscentrale*, which is operated by *Electrabel*, a subsidiary of *Engie* in the Dutch province of Groningen, is the oldest of currently three large power plants in the Energiepark Eemshaven on the west bank of the Ems estuary, directly at its outflow toward the East Frisian island of Borkum. With its installed electrical output of around 2.4 Gigawatts, this combined power plant is the most powerful power plant in the Netherlands.

Thanks to common competence in the ARCA Flow Group and close cooperation with *Von Rohr ARCA BV* from Deventer and *ARTES Valve & Service GmbH* from Velten, it was possible to convince the customer with its demanding project from both a technical and commercial aspect.

The equipment consists of a total of almost 90 dehydration and desalination valves consisting of shut-off and control applications for the blocks EC3 to EC7. Frequent load changes in the power plant in daily demand in combination with pressure differences of up to 100 bar(g) and operating temperatures of up to 500 °C, as well as the associated negative fluid effects of cavitation and flashing, place a particularly high demand on the wear resistance of the actuator and control valves.

In order to meet the increased customer requirements for service life and leakage class, the design of the control ball valve offers the following advantages here, among others:

- Separation of the functional levels “seal and control” by sealing the medium with the seat ring on the ball on the inlet side and the control on the regulating disc on the outlet side.
- The use of chrome carbide coatings on the ball and seat ring generates a particularly wear-resistant surface, which sets standards with a Vickers hardness of approx. 1100 HV.
- The straight-line passage through the valve avoids wear damage to pressure-bearing components inside the valve.

The acquisition of the project was made possible by the plant-specific expertise and the close customer contacts of the employees of *Von Rohr ARCA BV* with the decision-makers at *Eemscentrale*.

The bundling of competence and the performance capability within the ARCA Flow Group ultimately secured the contract and gave the green light for the project handling phase.

Schematic illustration of a regulating disc in the outlet of the control ball valve (©mtmedia.de)



THE COLOSSUS OF MÜRLENBACH

24 metric tons of turning and milling high-tech

An important new centerpiece found its place in FELUWA's production in October 2022: the Reiden RX12 machining center, a machine of superlatives.

The compact colossus with a dead weight of about 24 metric tons is a 5-axis milling/turning machining center with a pallet changer concept. The RX12 is capable of milling and machining components with larger dimensions and a higher weight in 5 axes. This enables the faster manufacture of necessary components in fewer steps.

In addition, numerous components whose production was previously dependent on external partners can now be manufactured directly at the company's headquarters. Your advantage: faster production of components on site. This minimizes bottlenecks in deliveries of components and materials and ensures more independent production of positive displacement pumps at the Mürlenbach site for our customers.



With the current investment we are expanding high-quality manufacturing on site – with increased efficiency, lower costs and a better energy balance thanks to shorter transport routes.

For *Ralf Scherer*, Managing Director Sales & Marketing, this is a promising step for the future: "This is one of the most important investments in the Mürlenbach site in recent years, and at the same time the largest investment ever made in a single machine in the long history of FELUWA Pumpen GmbH."

The colossus in action:

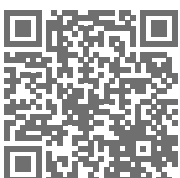

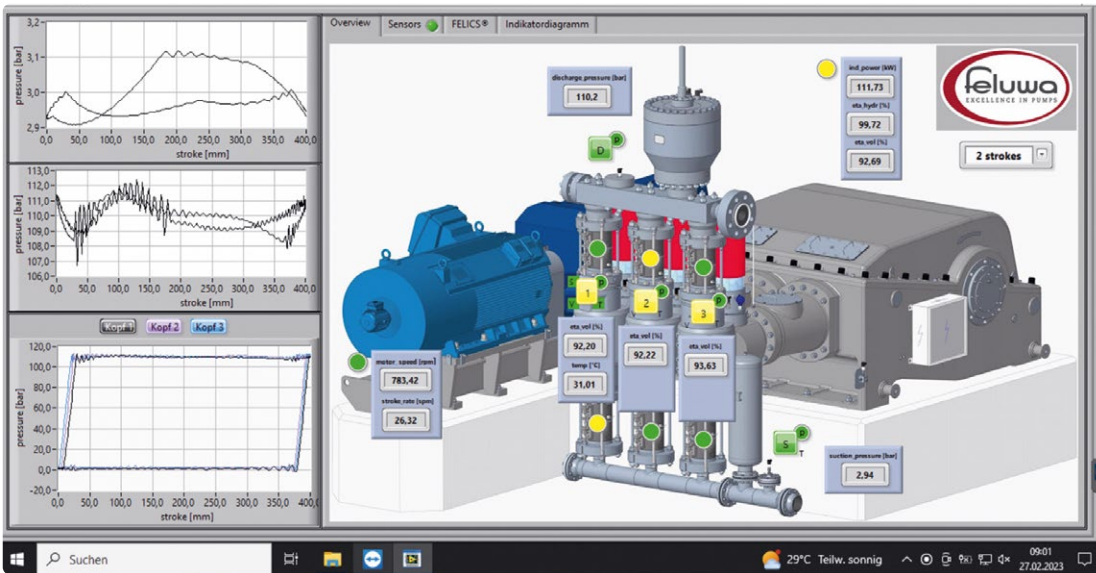

FELICS® – IT DOESN'T GET ANY CLEVERER THAN THIS

Smart pump monitoring

FELUWA is working continuously on the next generation of intelligent diagnostic and remote maintenance systems for holistic monitoring of the pump system. The newly developed FELICS® (FELUWA Indicator Condition Monitoring System) – a combination of integrated pump sensors and software-based evaluation – provides the user with detailed and up-to-date information on the performance and condition of the pump. Malfunctions and wear and tear are thus detected at an early stage before they lead to an unscheduled shutdown.

This innovation is based on a dynamic measuring system that records the developments of operating pressure, suction pressure, pressure in the pump chamber and the piston position over time, evaluating the data via a hybrid soft sensor. It can be used to compile an indicator diagram to display the pressure curve in the pump head as a function of piston position.

Over a period of four years, the FELUWA technical department developed a comprehensive evaluation algorithm, tested it within a test environment and during a prototype phase. This year's task is to bring the system to market maturity and series production. FELUWA relies on a hardware infrastructure with an IPC (industrial PC) to run the evaluation algorithm programmed in the high-level language C# as a basis for the new measuring system.

With FELICS®, up to 67 different pump malfunctions can already be automatically detected, for example valve damage, pulsation or the beginning of sedimentation. This "all-round carefree package" will be available for FELUWA customers from the middle of the year.

GROWING ON THE JOB: PCG SMART COMPACT

Small pump control for FELUWA pumps

FELUWA not only has a new development in terms of monitoring for large pumps: the small pump control has also been completed. In addition to functionality, cost minimisation was particularly important here, as these were almost identical to those of the large FELUWA pumps for the control systems previously used. However, while the cost share is only in the low single-digit percentage range for the latter, the share of the total costs for the control unit was considerably higher for the small pumps. As a result, most pump sales did not include a control unit and the associated advantages, such as pump operation at maximum efficiency or early diagnosis of faults, were never available for the customers.

This is why FELUWA initiated the development of a control unit with integrated diagnostics which is especially designed for small pumps. The greatest innovation is the introduction of analogue inputs and outputs, which are required for the control of the optional frequency converter or for

communication with the customer's higher-ranking control system. Besides, the enlargement of the touch panel also ensures better operability and readability for the customer.

Precisely reviewing the hardware for EMC (electromagnetic compatibility) to ensure that the control unit does not fail in the (usually) rough everyday operating conditions is just as important as a reliably working software. All measurement results were within the limits defined in the applicable standards. We are now ready to take the final step.

FELUWA customers receive the small pump controller embedded in a control cabinet. The newly created overall system is named *PCG SMART Compact* and has been distributed since the beginning of the year.

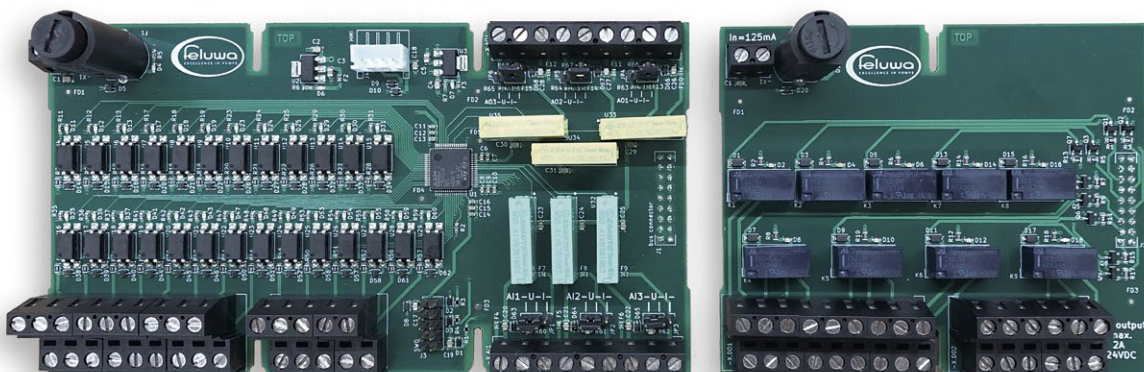

This is what our PCG SMART Compact looks like – it improves the cost-effectiveness of the pump operation by means of a clever digital control

FELUWA focuses on digitization in service and after-sales

According to a current study, service quality accounts for up to 50% of an investment decision, the same proportion as product quality and price combined. In addition, it is of central importance for FELUWA to offer a dependable service for customers worldwide. The company relies on digitization of service with the help of a special XRM software in order to offer targeted support to existing customers and to further increase customer satisfaction.

The XRM software has many advantages: It increases transparency in the “pump life cycle”, e.g., regarding operating data, changes, and spare parts, while also documenting after-sales. Deployment planning, damage analysis and service reports will be available digitally in a single system in the future, putting an end to handwritten reports.

SERVICE 4.0

XRM (Extended Relationship Management) shifts the focus from customer administration to the pumps which have been delivered. In a single system all processes for FELUWA service and spare parts distribution are mapped.

An integrated ticketing system ensures transparent tracking and quicker processing of customer enquiries. In perspective, it is even planned that the customers will be able to access their own FELUWA customer portal.

The data acquired from the XRM system will not only be used to build a knowledge database, but also for continuous development and improvement of the pumps. Everything is aimed at optimally exploiting the full potential of service and after-sales – for maximum customer satisfaction.

The XRM system was put through its paces at FELUWA in a four-month pilot phase (September to December 2022) and has been in service since the beginning of the year.

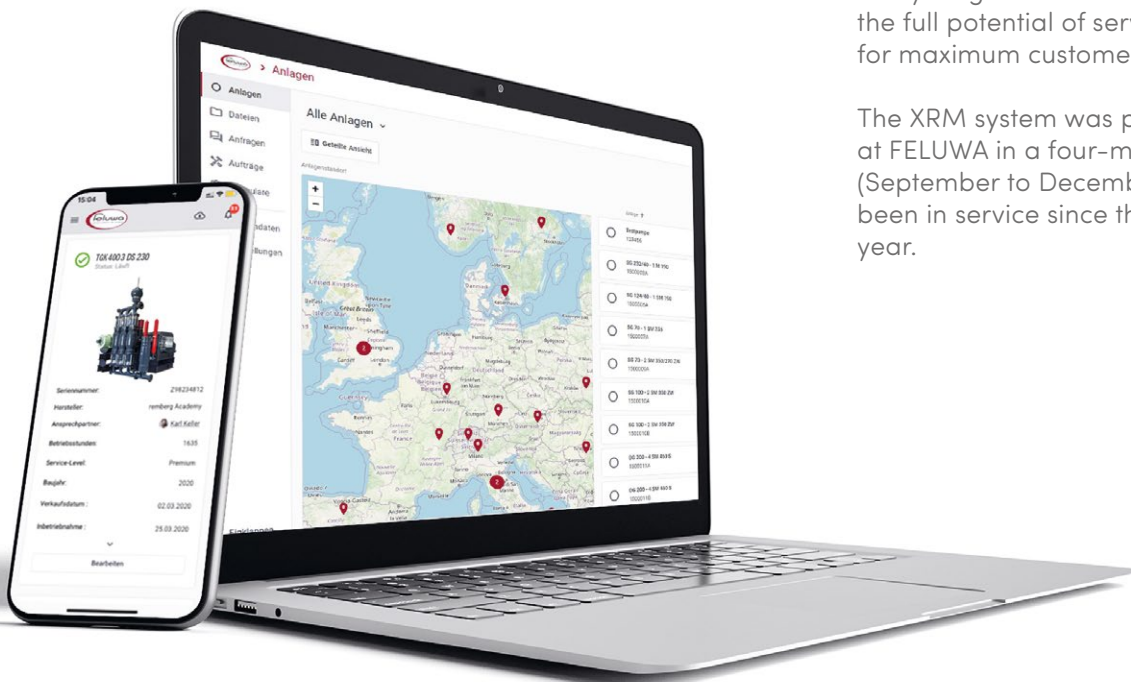

How to reduce dependencies in production and increase flexibility in manufacturing

According to *statista*, Switzerland stands for typical Swiss values even in the country itself. Safety is in first place, precision in fifth. We were able to incorporate both values in a project for 175 on/off and control valves from the 8B series, because safety and precision are fundamental to all our control valves.

We were particularly proud that we were able to do this for the pharmaceutical and chemical industries in our own country. After the recent global pandemic in Europe and Switzerland showed the importance of production facilities in one's own country in order to reduce dependencies and risks of outsourcing and to remain efficient, the re-think has also reached our precision control valves.

Various Swiss companies announced their expansion plans last year. For this reason, the sales team at von Rohr Armaturen AG held intensive discussions with a number of engineering offices last year – including for the aforementioned major project. Following lengthy, detailed negotiations, von Rohr Armaturen was awarded the contract. Very Swiss – we can't divulge any details at this point due to confidentiality agreements, but we can at least reveal this:

the main arguments for the Group winning the contract were above all our quick responses in conjunction with consulting depth, suitable solution proposals and a high degree of flexibility. In accordance with the agreement with the customer, the delivery took place as smoothly as the subsequently regulated process at the Group itself.

SWISS PRECISION WORK

All of this has been seamlessly integrated into our order backlog, which shows in terms of weakening supply chains and pandemic conditions that Switzerland can be relied upon.

Which brings us, last but not least, to chocolate – 8th place in the list of typical Swiss characteristics – because, of course, we can control its production with our quality valves, too.

You can find all the good reasons for Swiss control quality with a pneumatic actuator here:



Series 8B

DN 15–100 / ½"–4" /

PN 16–40 /

ANSI Class 150–300 /

Temperature range -196 °C to 450 °C



HYDROGEN EXPERTISE SINCE 2005. FOR 2055.

The future is written with H₂

Hydrogen is considered the energy source of the future – which has been invoked for years. But it was only the changed framework conditions, such as a disruptive energy market and the energy shortage in Europe, that increased the pressure to act towards alternative energy sources.

This will also give new impetus to the ecological transformation, which already called for global net greenhouse gas emissions in the 2015 Paris Climate Agreement. Energy shortages and the transformation towards green technologies have significantly increased the acceptance of hydrogen in business and society. The focus is no longer on if, but on how and when.

We note: at the latest with the energy change, hydrogen is no longer a topic of the future, but has arrived in the present. It's a good thing that WEKA has already made this development its topic in the past.



As early as 2005 we were involved in liquid hydrogen control for the car manufacturer Opel and provided innovative process solutions. We have built on this and since then have been advancing our technical expertise and experience in the control of the element H₂.

That is why reliable components for the entire H₂ value chain are now a specialty of our company. This is also reflected in our ambitious planning: as early as 2027, 50 percent of WEKA's total sales are to be generated with hydrogen solutions.

Worldwide boom – our business

Not only the EU, but the whole world is moving with the development of a hydrogen infrastructure. Worldwide, 680 large-scale hydrogen projects have currently been announced (as of March 2023); 160 of them since 2021 alone. 534 projects are expected to be fully or partially operational by 2030. This corresponds to about 240 billion US dollars in direct investments in the new energy source and its value chains by 2030.

By 2050, global production is forecast to reach 160 million metric tons of green hydrogen. A significant increase is also expected for blue hydrogen: 80 million metric tons could be produced in 2050. Every third project is taking place in Europe – WEKA AG's most important target market.

WEKA's customers like to think big

Some of the world's largest projects are being implemented by our existing customers. For example, Air Liquide and Siemens Energy are planning to build a 30-megawatt electrolysis plant for the production of climate-neutral hydrogen in Oberhausen, Germany. In the initial phase, the plant with a capacity of 20 MW is scheduled to go into operation as early as 2023.

Hydrogen has energy potential for many applications – all of which need to be safely controlled.



Linde plans to put a 35 MW electrolysis plant into operation in New York State in 2025. We would like to take this opportunity to mention again our role as a technical supplier of space infrastructure, in particular to the European Space Agency (ESA). Our special manual and control valves are used in the ARIANE launcher fuel filling system in French Guiana (see also page 4 in this ARCAristics).

WEKA AG: hydrogen experts

As you have read so far, WEKA can offer you long-term expertise in expanding your hydrogen infrastructure for production, transport, usage and storage: as a valve manufacturer, our product range already covers all parts of the hydrogen value chain, both for liquid and gaseous hydrogen. One of the challenges we face is the development of components that is always dependent on the manufacturing process. You benefit here from more than 17 years of experience in hydrogen handling.

Here, too, our company impresses with great flexibility and tailor-made solutions.



ECOTROL®
Series 8C
DN15 – DN100
PN16 – PN63
-196°C to 650°C



ARCASMART
Series 826
4 – 20 mA
digital communication
-20°C to 80°C



POWERROL
Series 500
DN15 – DN800
PN16 – PN400
-10°C to 650°C



ARCADRIVE
Series 812
Diaphragm area up to 720 cm²
Spring force up to 16 kN
Stroke 10 to 60 mm



BIOVENT®
Series 391
DN15 – DN150
PN10 – PN25
-30°C to 135°C

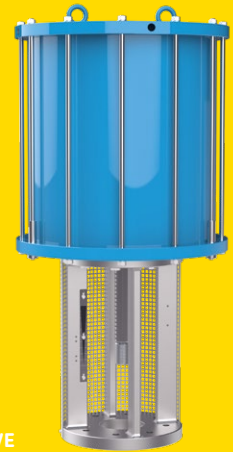

ARCADRIVE
Series 814
Piston area up to 2.825 cm²
Spring force up to 22 kN
Stroke 180 to 250 mm



ANGLEVENT
Series 340
DN15 – DN300
PN10 – PN40
-196°C to 650°C



FORGEVENT
Series 190
DN15 – DN65
PN100 – PN400
-29°C to 650°C